

PORSCHE

2014 - 2015 911 GT3

2013 - 2015 911 *(from Software Version 4.xx ONLY)*

2014 - 2015 Boxster *(from Software Version 4.xx ONLY)*

2008 - 2015 Cayenne

2014 - 2015 Cayman *(from Software Version 4.xx ONLY)*

2010 - 2015 Panamera

Disclaimer: Depending on the HW version of your PCM system, this product may not support some versions.

APPLICATION NOTES:

ONLY FOR VEHICLES WITHOUT FACTORY REAR-VIEW CAMERA

WORKS FOR:

PCM 3.1 NAVIGATION RADIOS

PCM 3.0 NAVIGATION RADIOS (Cayenne Only)

Internal DVD player will not be able to be watched while in motion.

SAFETY PRECAUTIONS

1. Please read through the entire instruction manual before starting any of the installation procedures.
2. We recommend disconnecting the negative side of the battery until ready to code the vehicle.
3. Do not install any of the main modules near any major components or near the HVAC system, as placing items near the HVAC may cause damage or overheating to the vehicle or interface.
4. We recommend not disconnecting any of the air bag connections behind the dash panels.
5. This product is under Crux's 1 year manufacturer's warranty. Warranty may be voided in the case where the device shows proof of being opened or improper extreme force.



### INSTALLATION OVERVIEW

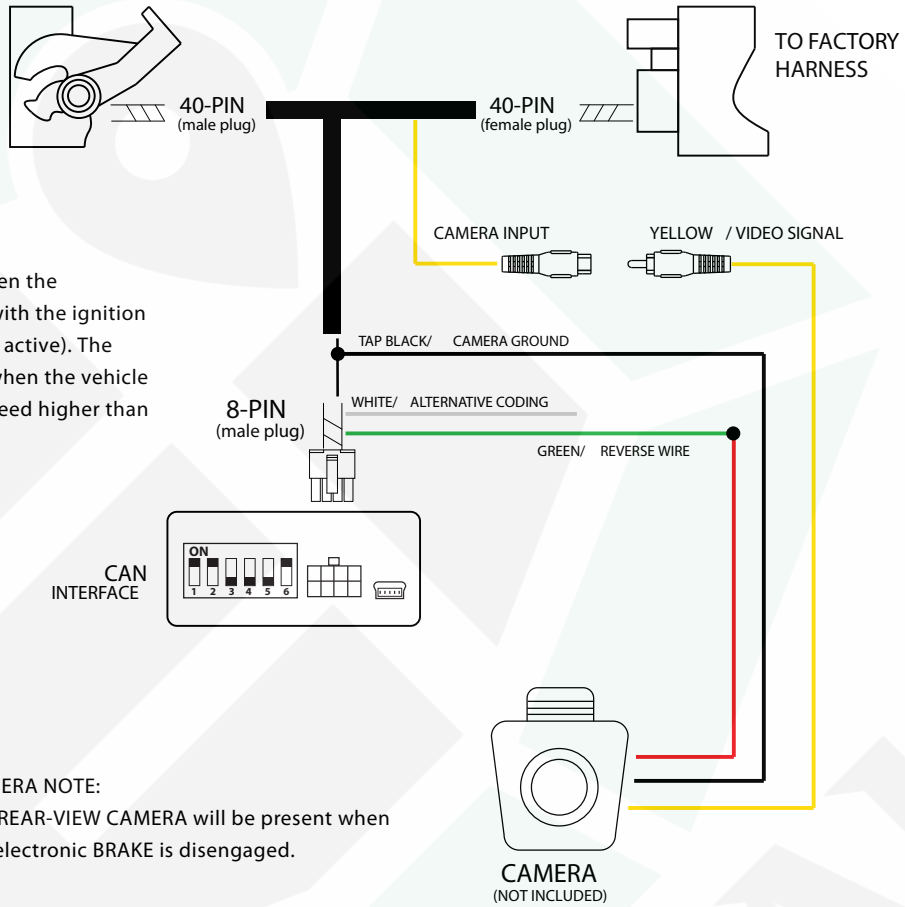

#### NOTE ABOUT THE GREEN WIRE:

The GREEN wire provides 12v when the REVERSE gear is engaged (Even with the ignition OFF, the vehicle's CAN-BUS is still active). The GREEN wire will be deactivated when the vehicle is placed into DRIVE and has a speed higher than 10mph.

#### CAMERA NOTE:

The REAR-VIEW CAMERA will be present when the electronic BRAKE is disengaged.

#### DIP SWITCHES OVERVIEW

Make sure to set dip switch number 6 to "ON" position.

For the RVC feature, you will only need to set dip switch "2" to ON.

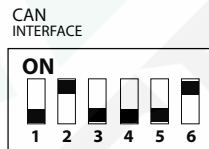

#### VIDEO IN-MOTION

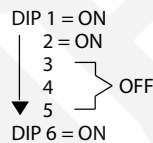

#### NO VIDEO IN-MOTION

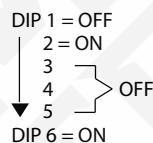



#### CONNECTING THE INTERFACE

Follow these steps to properly install interface module.

**Step 1** - Remove the factory radio to gain access to the factory 40-Pin connector.

Remove the factory 40-Pin connector. Your radio face may differ.



**Step 2** - Prior to connecting the interface, we recommend taping the 4 wires necessary to power the module.

Connect the 4 loose wires from the harness to the 4 designated wires on the factory 40-Pin connector.

#### Factory Connector Pin Assignments

COLOR	DESCRIPTION	TAP PIN
RED =	12V CONSTANT	15
BLACK =	GROUND	12
ORANGE/BROWN =	CAN-LOW	9
ORANGE/PURPLE =	CAN-HIGH	11

Emerald Integrations and Crux holds no liability for the vehicle wiring color codes and pin ration.

As there may be changes by the vehicle manufacturer that we may not be aware of. Installer must verify this information prior to being installed.

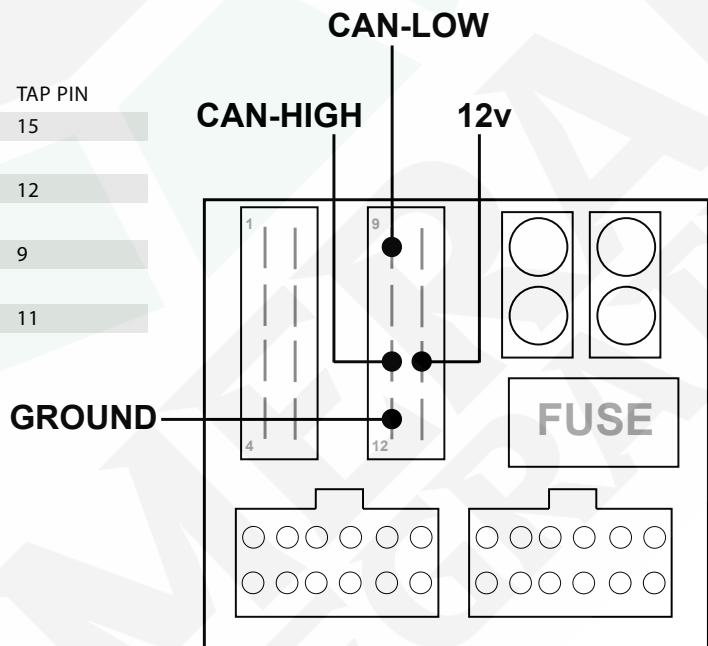

## INSTALLING THE INTERFACE

Follow these steps to properly install the interface module. Prior to installing the interface we recommend disconnecting the negative side of the battery. Use a resistor lead if needed, as the manufacturer does not suggest disconnecting the battery cable.

- Step 3 - Connect the module to the 8-Pin connectors on the provided T-Harness.  
Make sure your connection is firmly inserted into the module.



- Step 4 - Mate the 40-Pin T-harness connections, to the factory harness and to the back of the factory radio.  
After connecting the module, set dip switch number "6" to the "ON" position. (Latch locks and releases harness)





#### CODING THE VEHICLE

In order to activate the Rear-View Camera feature, the installer must CODE the car first.

Step 5 - While listening to the FM Source, place dip switch number "2" to the "ON" position on the module.  
The screen will power-off and begin to reset.



#### DIP SWITCH DESCRIPTION LOCATED ON THE CAN MODULE.

UP=ON       DOWN=OFF

- DIP 1 = Video In-Motion Enable
- DIP 2 = Factory Rear-View Camera
- DIP 3 = Code Rear-View Cam w/ White Wire
- DIP 4 = Code Park Assist w/ White Wire
- DIP 5 = Not Used
- DIP 6 = Can-Bus Termination

#### LED INDICATORS

**DATALINK LED:**  
Blinking = BUS Detected.  
OFF = Power Down/ Sleep mode.

**POWER LED:**  
ON = Power On  
OFF = Power OFF

After each change of the DIP switch settings, we recommend powering down the module, then restarting the vehicle.

#### TECH TIP:

IN THE CASE THAT THE VEHICLE IS MANUAL TRANSMISSION, THE INTERFACE WILL NOT PROVIDE YOU THE REVERSE OUTPUT. YOU WILL NEED TO TAP THE CARS REVERSE LIGHT TO THE GREEN WIRE FROM THE 8-PIN CONNECTOR ON THE MODULE.

- Step 1. Remove the GREEN wire (Pin 2) from the 8-Pin connector.
- Step 2. Connect the GREEN wire to the REVERSE light from the car. We recommend using a DIODE when connecting.
- Step 3. Make sure nothing is populating Pin 2 on the 8-Pin connector.

TO REVERSE LIGHT  
CATHODE TOW ARDS LIGHT

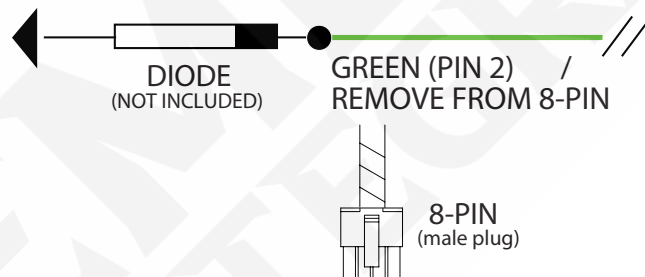



#### CODING THE VEHICLE

In order to activate the Rear-View Camera feature, the installer must CODE the car first.

Step 6 - With the T-Harness and interface module properly connected, turn the ignition to the "ON" position. Wait for the head unit to power on then proceed to the following steps.

On the left side of the steering wheel:

1. Press and Hold both the "Hash Key" and "Answer" buttons for 10 approx. 10 seconds.

During the coding process, the Red and Blue LED will begin to flash.

2. After the head unit has began to reset, release both buttons.

The Red and Blue LED's will glow solid to identify the coding has been completed.



Step 7 - With the interface coding successful, you will be able to enter the menu structure and see "Rear-View Camera" in the menu structure.





Step 8 - Now you may proceed to installing the Rear-View Camera. Make sure to use the 8-Pin connector for REVERSE and GROUND for the camera. (See Installation Overview) Note: The vehicle display offers a Zoom + and Zoom - option, this interface does not support this option.

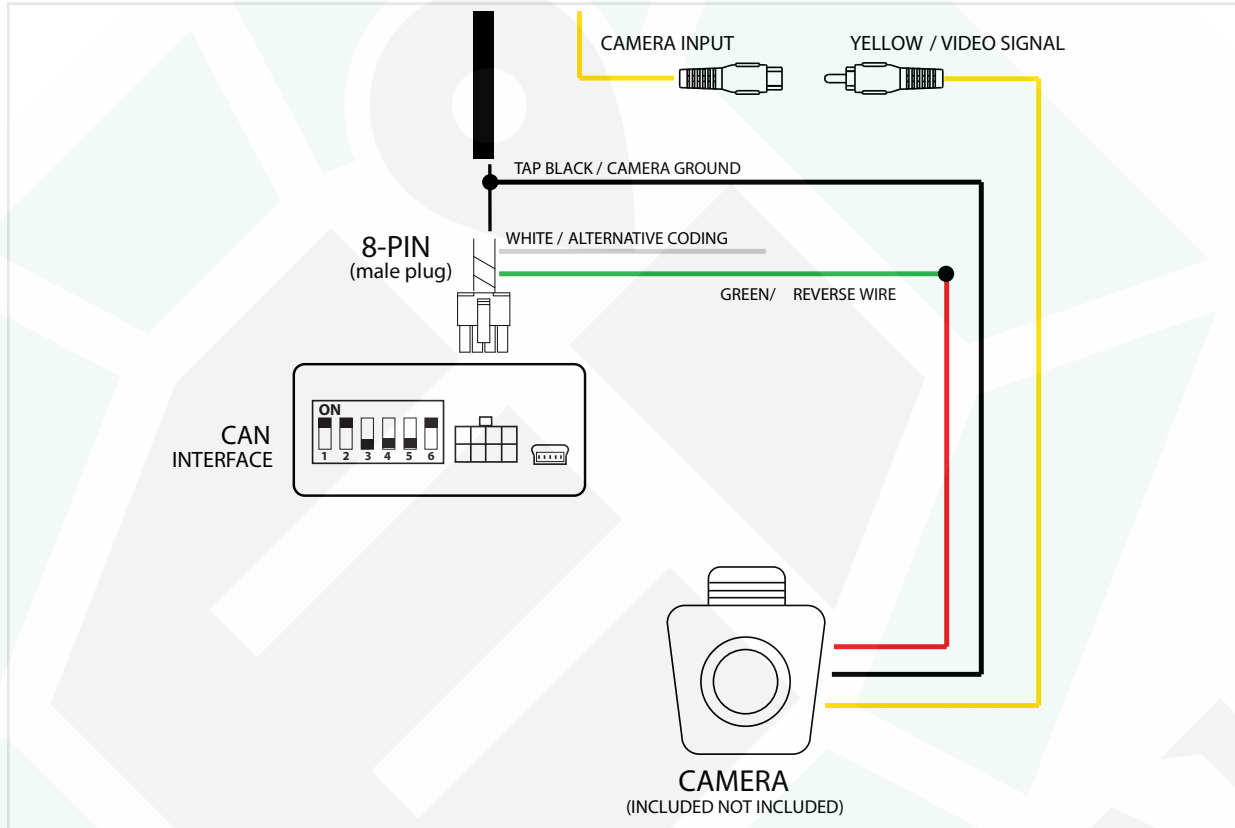

### DECODING THE VEHICLE REAR-VIEW CAMERA

In the case where you need to decode the aftermarket rear-view camera input, please do the following:

Step 9 - With the T-Harness and interface module properly connected, turn the ignition to the "ON" position. Wait for the head unit to power on then proceed to the following steps.

On the left side of the steering wheel:

1. Press and Hold both the "Hash Key" and "End Call" buttons for 10 approx. 10 seconds. (See page 5 for HASH Key) During the coding process, the Red and Blue LED will begin to flash.
2. After the head unit has began to reset, release both buttons. The Red and Blue LED's will glow solid to identify the coding has been completed.

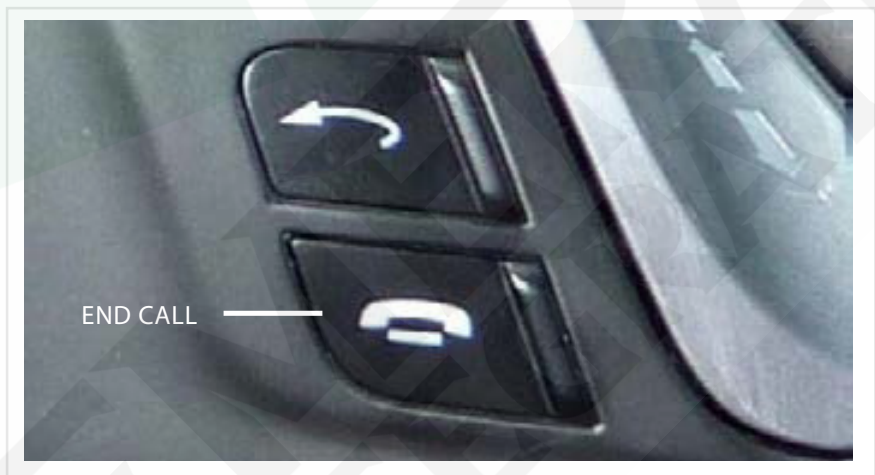



### ACTIVATING THE VIDEO IN-MOTION

To activate the Video In-Motion please do the following.

Option 1 - Permanent Activation: By activating dip switch number "1" to the "ON" position the Video In-Motion is permanently active.

Note: Having the Video In-Motion active will not affect the GPS performance.

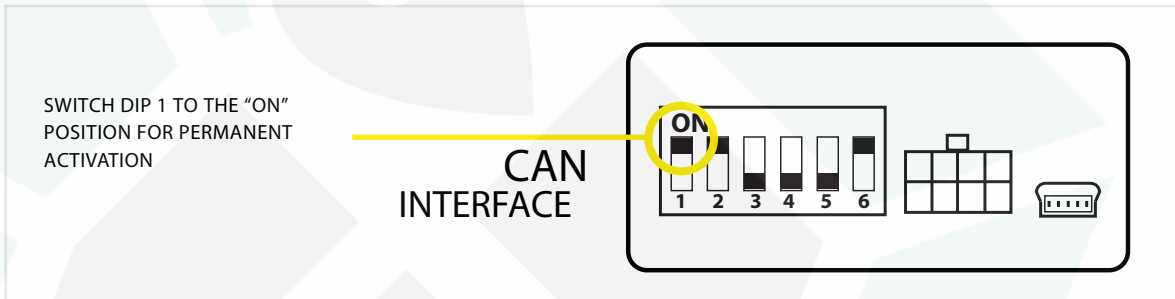

### CODING AND DECODING OPTIONS

You must code the park assist in order to retain.

#### CODING THE PARK ASSIST

Its necessary to code the vehicle in order to activate the factory Park-Assist, if equipped from the factory.

Step 1 - With the T-Harness and interface module properly connected, turn the ignition to the "ON" position. Wait for the head unit to power on then proceed to the following steps.

On the steering wheel:

1. Press and Hold both the "BACK" and "ANSWER" buttons for 10 approx. 10 seconds.  
During the coding process, the Red and Blue LED will begin to flash.
2. After the head unit has began to reset, release both buttons.  
The Red and Blue LED's will glow solid to identify the coding has been completed.

#### DECODING THE PARK ASSIST

In case you may need to remove the interface, here is how you decode the Park-Assist.

Step 1 - With the T-Harness and interface module properly connected, turn the ignition to the "ON" position. Wait for the head unit to power on then proceed to the following steps.

On the steering wheel:

1. Press and Hold both the "BACK" and "END CALL" buttons for 10 approx. 10 seconds.  
During the coding process, the Red and Blue LED will begin to flash.
2. After the head unit has began to reset, release both buttons.  
The Red and Blue LED's will glow solid to identify the coding has been completed

THE PARK ASSIST OPTION WILL NO LONGER BE AVAILABLE ON THE MENU.

**USING THE WHITE WIRE TO ACTIVATE THE REAR-VIEW CAMERA AND/OR PARK ASSIST**

Aside from coding the vehicle using the Steering Wheel Controls, you can code the vehicle using the loose WHITE wire on the CAN module and dip switches 3 and 4.

Dip 3 = Rear-View Camera Enable

Dip 4 = Park Assist Enable

**Step 1** - With the T-Harness and interface module properly connected, turn the ignition to the "ON" position.  
Wait for the head unit to power on then proceed to the following steps.

On the CAN module:

1. Set dip switches 3 and 4 on the CAN module ON or OFF  
(Depending on Coding or Decoding)
2. Place 12V on the WHITE wire for approx. 5 Seconds.  
During the coding process, the Red and Blue LED will begin to flash.
3. After the head unit has began to reset,  
release both buttons.  
The Red and Blue LED's will glow solid  
to identify the coding has been  
completed.

THE PARK ASSIST ND REAR-VIEW CAMERA  
OPTION WILL BE AVAILABLE ON THE MENU.

After coding is complete, you must wait 60 seconds until trying to code or decode the vehicle again.





### COMPATIBLE RADIOS

